

## 2005-2009 GM Legacy LS2 ECM Installation Instructions

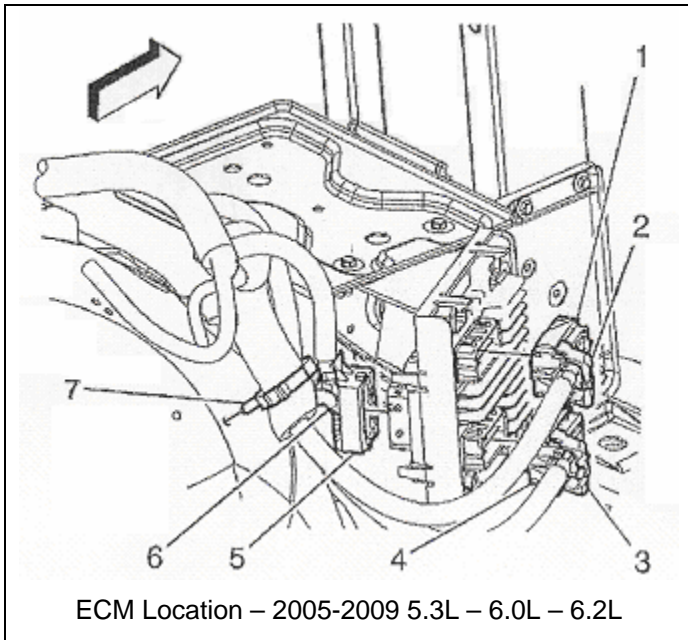

Disengage the engine wiring harness upper electrical connector retainer (2) and remove the connector (1) from the ECM.

Disengage the engine wiring harness lower electrical connector retainer (3) and remove the connector (4) from the ECM.

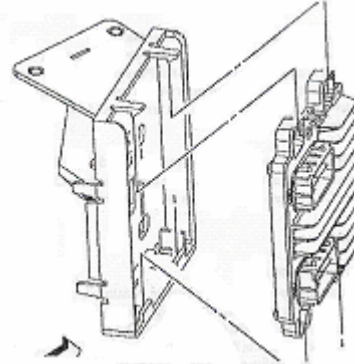

Re-install in reverse order. Make sure the connectors are seated properly before tightening them to avoid bending any pins in the ECM.

### 30-MINUTE LEARN PROCEDURE

1. Turn ON the ignition, with the engine OFF. Attempt to start the engine, then release the key to ON, vehicle will not start.
2. Observe the SECURITY telltale. After approximately **10 minutes**, the telltale will turn OFF.
3. Turn OFF the ignition and wait **5 seconds**
4. Repeat steps 1 through 4 two more times for a total of 3 cycles/**30 minutes**. The vehicle is now ready to relearn the Passlock™ Sensor Data Code and/or passwords on the next ignition switch transition from OFF to CRANK.
5. Start the engine. The vehicle has not learned the Passlock™ Sensor Data Code and/or password.

**IMPORTANT:** The vehicle learns the Passlock™ Sensor Data Code and/or password on the next ignition switch transition from OFF to CRANK. You must turn the ignition OFF before attempting to start the vehicle.

### DTC PO315

#### CIRCUIT DESCRIPTION

The crankshaft position (CKP) system variation learn feature is used to calculate reference period errors caused by slight tolerance variations in the crankshaft, and the CKP sensor. The calculated error allows the powertrain control module (PCM) to accurately compensate for reference period variations. This enhances the ability of the PCM to detect misfire events over a wide range of engine speed and load. The PCM stores the Crankshaft Position System Variation values after a learn procedure has been performed. If the actual crankshaft position variation is not within the Crankshaft Position System Variation compensating values stored in the PCM, DTC PO300 may set. If the CKP system variation values are not stored in the PCM memory, DTC PO315 sets.

**IMPORTANT: The Crankshaft Position Variation Learn Procedure may have to be repeated up to 5 times before the procedure is learned.** Perform the Crankshaft Position (CKP) System Variation Learn Procedure. Refer to CKP System Variation Learn Procedure. Does the scan tool display Learned this ignition?

### CKP SYSTEM VARIATION LEARN PROCEDURE

1. Install a scan tool
2. Monitor the powertrain control module (PCM) for DTC's with a scan tool. If other DTC's are set, except DTC PO315, refer to Diagnostic Trouble Code (DTC) List – Vehicle for the applicable DTC.
3. Select the crankshaft position variation learn procedure with a scan tool.

4. The scan tool instructs you perform the following:
  - a. Accelerate to wide open throttle (WOT)
  - b. Release throttle when fuel cut-off occurs.
  - c. Observe fuel cut-off for applicable engine.
  - d. Engine should not accelerate beyond calibrated RPM value.
  - e. Release throttle immediately if value is exceeded.
  - f. Block drive wheels.
  - g. Set parking brake.
  - h. DO NOT apply brake pedal.
  - i. Cycle ignition from OFF to ON.
  - j. Apply and hold brake pedal.
  - k. Start and idle engine.
  - l. Turn the A/C OFF.
  - m. Vehicle must remain in Park or Neutral.
  - n. The scan tool monitors certain component signals to determine if all the conditions are met to continue with the procedure. The scan tool only displays the condition that inhibits the procedure. The scan tool monitors the following components:
    - Crankshaft position (CKP) sensors activity – If there is a CKP sensor condition, refer to the applicable DTC.
    - Crankshaft position (CKP) signal activity – If there is a CMP signal condition, refer to the applicable DTC.
    - Engine coolant temperature (ECT) – If the engine coolant temperature is not warm enough, idle the engine until the engine coolant temperature reaches the correct temperature.
5. Enable the CKP system variation learn procedure with the scan tool.
6. Accelerate to WOT.

**IMPORTANT:** While the learn procedure is in progress, release the throttle immediately when the engine starts to decelerate. The engine control is returned to the operator and the engine responds to throttle position after the learn procedure is complete.

7. Release throttle when fuel cut-off occurs.
8. The scan tool display reads "Test In Progress".
9. The scan tool displays Learn Status: Learned this ignition. If the Scan tool indicates that DTC PO315 ran and passed, the CKP variation learn procedure is complete. If the scan tool indicates DTC PO315 failed or did not run, refer to DTC PO315. If any other DTC's set, refer to Diagnostic Trouble Code (DTC) List – Vehicle for the applicable DTC.
10. Turn OFF the ignition for **30 seconds** after the learn procedure is completed successfully.
11. The CKP system variation learn procedure is also required when the following service procedures have been performed, regardless of whether or not DTC PO315 is set:
  - An engine replacement
  - A PCM replacement
  - A harmonic balancer replacement
  - A crankshaft replacement
  - A CKP sensor replacement
  - Any engine repairs which disturb the crankshaft to CKP sensor relationship.

The computer can take as much as 5-6 tanks of fuel and 200 or more miles of driving to fully learn itself to where best performance and mileage is attained.

